

PIR SENSOR INTERFACE February 2014

FEATURES:

- Low Quiescent Current
- Direct Interface with PIR Sensor
- Two-Stage Differential Amplifier
- Amplifier Gain and Bandwidth externally controlled
- Window Comparator and Digital Filter limit Noise
- Triac or Relay Output Drive
- Programmable Output Duration Timer
- Ambient Light Level Inhibit input
- Selectable Dead Time
- Single or Dual Pulse Detection
- Timing derived from RC Oscillator or 50Hz/60Hz AC
- Regulated 5V Output for PIR Sensor
- Motion Detection LED Indicator
- LS6522 (DIP); LS6522-S (SOIC-NB); LS6522-SW (SOIC-WB) - See Figure 1

APPLICATIONS:

Indoor occupancy sensors and outdoor motion-triggered lighting for energy savings, security and convenience.

DESCRIPTION: (See Figure 2)

The LS6522 is a CMOS integrated circuit, designed for detecting motion from a PIR Sensor and initiating appropriate responses. The detailed description of the functional blocks is as follows:

DIFFERENTIAL AMPLIFIER

Each stage of the two stage Differential Amplifier can be set to have its own amplification and bandwidth. The two inputs to the first stage allow for single ended or differential connection to PIR Sensors. This stage can be biased anywhere in its dynamic range. The second stage is internally biased so that the Window Comparator's lower and higher thresholds can be fixed relative to this bias.

WINDOW COMPARATOR

The Window Comparator provides noise filtering by enabling only those signals equal to or greater than a fixed threshold at the output of the Differential Amplifier to appear at the output of the Window Comparator.

COMPARATOR DIGITAL FILTER

The output of the Window Comparator is filtered so that motion must be present for a certain duration before it can be recognized and appear as pulses at the Digital Filter output.

PIN ASSIGNMENT - TOP VIEW

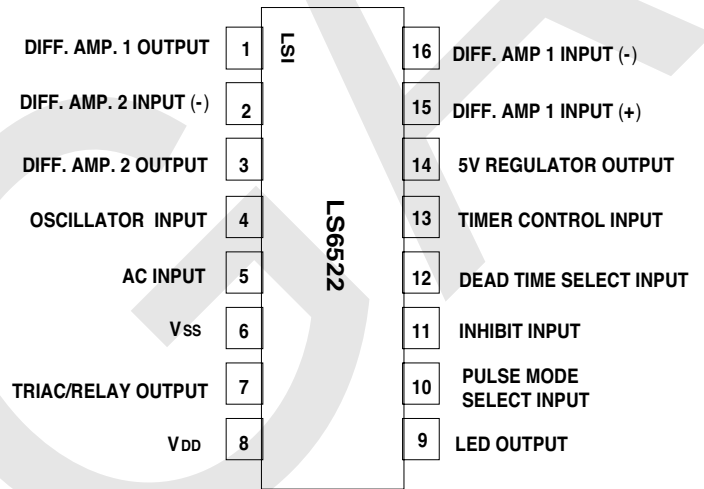

FIGURE 1

OUTPUT DURATION TIMER

The voltage level at the TIMER CONTROL input can select 16 different timeouts for this Timer (See Table 1). The selection can be made by varying the setting of a potentiometer. The Timer is retriggerable and controls the ON duration of the TRIAC/RELAY output. The trigger for the Timer is generated from pulses appearing at the Digital Filter output.

SINGLE PULSE/DUAL PULSE MODES

A Single Pulse or Dual Pulse (two pulses occurring within a specified time period) at the Digital Filter output can be selected as the trigger for the Output Duration Timer. This selection is made by the logic level at the PULSE MODE SELECT input. Logic 0 = Single Pulse Mode, logic 1 = Dual Pulse Mode.

LED OUTPUT

This is an open drain output which is turned on by pulses generated by a retriggerable one-shot. The one-shot is triggered by the leading edge of pulses appearing at the Digital Filter output. When turned on, this output can sink current from a series Resistor-LED network returned to a positive voltage (V_{DD} to 12.5V maximum). This results in the LED lighting whenever motion is detected.

INHIBIT

The Output Duration Timer can be inhibited from triggering by the voltage level at the INHIBIT input. When this voltage level exceeds the Inhibit Threshold, the Timer will be prevented from triggering if it is OFF. If the Timer is ON, the INHIBIT input is blocked from affecting the Timer. There is approximately 10% hysteresis between the Inhibit and Enable thresholds at the INHIBIT input. The LED output is not affected by the INHIBIT input. An adjustable Ambient Light Level Inhibit can be implemented by connecting a Light Determining Resistor (LDR) network to the INHIBIT input (See Figures 3 and 4).

DEAD TIME

False turn-ons are prevented from occurring by establishing a Dead Time between the end of the timeout of the Output Duration Timer and the retriggering of that Timer. The state of the DEAD TIME SELECT input determines the Dead Time duration (See Table 2).

OSCILLATOR

For battery operation, an external RC is connected to the OSCILLATOR input to produce a 50Hz or 60Hz clock. A 30Hz clock can be used to extend timing durations (See Tables 1 and 2).

DC POWER SUPPLY

V_{DD} - V_{SS} is 8V ± 1V. Typical quiescent current is 250µA (TRIAC/RELAY, LED and REGULATOR outputs not loaded).

DC REGULATOR

The LS6522 includes a Regulator which provides a nominal +5V to the Differential Amplifier and Window Comparator and is available as an output to supply the PIR Sensor.

TRIAC/RELAY OUTPUT

This open drain output turns ON when the Output Duration Timer is triggered. The output drives a Triac when the OSCILLATOR input is tied to ground and 50/60Hz is applied to the AC input (See Figure 3). The output drives a Relay when the AC input is tied to ground and an RC network is connected to the OSCILLATOR input (See Figure 4).

TRIAC DRIVE (See Figure 3)

With the Output Duration Timer ON and a 2.7V P-P 60Hz signal applied to the AC input, the output produces a negative-going pulse in each half-cycle delayed a nominal 1.2ms from the zero crossing. There is no more than 150µs difference between the zero-crossing delay of each pulse.

RELAY DRIVE (See Figure 4)

The output can sink current continuously with the Output Duration Timer ON and the OSCILLATOR input active. This output can sink current from a relay coil returned to a positive voltage (V_{DD} to 12.5V maximum).

TABLE 1
OUTPUT DURATION TIMER AS A FUNCTION OF TIMER CONTROL INPUT VOLTAGE
(f = Frequency at AC input or OSCILLATOR input)

INPUT VOLTAGE	f = 30Hz	f = 50Hz	f = 60Hz	UNIT
0	30	18	15	sec
0.09 V _{DD}	60	36	30	sec
0.16 V _{DD}	90	54	45	sec
0.22 V _{DD}	120	72	60	sec
0.28 V _{DD}	4	2.4	2	min
0.34 V _{DD}	6	3.6	3	min
0.41 V _{DD}	8	4.8	4	min
0.47 V _{DD}	10	6	5	min
0.53 V _{DD}	12	7.2	6	min
0.59 V _{DD}	14	8.4	7	min
0.66 V _{DD}	16	9.6	8	min
0.72 V _{DD}	18	10.8	9	min
0.78 V _{DD}	20	12	10	min
0.84 V _{DD}	24	14.4	12	min
0.91 V _{DD}	28	16.8	14	min
V _{DD}	30	18	15	min

TABLE 2
DEAD TIME DURATION AS A FUNCTION OF THE STATE OF DEAD TIME SELECT INPUT
(f = Frequency at AC input or OSCILLATOR input)

INPUT STATE	f = 30Hz	f = 50Hz	f = 60Hz	UNIT
0	2	1.2	1	sec
OPEN	8	4.8	4	sec
1	16	9.6	8	sec

ABSOLUTE MAXIMUM RATINGS:

PARAMETER	SYMBOL	VALUE	UNIT
DC supply voltage	$V_{DD} - V_{SS}$	+10	V
Any input voltage	V_{IN}	$V_{SS} - 0.3$ to $V_{DD} + 0.3$	V
Operating temperature	T_A	-40 to +85	°C
Storage temperature	T_{STG}	-65 to +150	°C

ELECTRICAL CHARACTERISTICS:

(All voltages referenced to V_{SS} , $T_A = -40^{\circ}\text{C}$ to $+55^{\circ}\text{C}$, $7\text{V} \leq V_{DD} \leq 9\text{V}$, unless otherwise specified.)

PARAMETER	SYMBOL	MIN	TYP	MAX	UNIT	CONDITIONS
SUPPLY CURRENT:						
$V_{DD} = 8\text{V}$	I_{DD}	-	250	350	μA	TRIAC/RELAY, LED and REGULATOR outputs not loaded
$V_{DD} = 7\text{V} - 9\text{V}$	I_{DD}	-	300	420	μA	
REGULATOR:						
Voltage	V_R	4.0	-	5.5	V	-
Current	I_R	-	-	200	μA	-
DIFFERENTIAL AMPLIFIERS:						
Open Loop Gain, Each Stage	G	70	-	-	dB	-
Common Mode Rejection Ratio	CMRR	60	-	-	dB	-
Power Supply Rejection Ratio	PSRR	60	-	-	dB	-
Output Drive Current	I_D	-	-	25	μA	-
Input Sensitivity (Minimum Detectable Voltage to first amplifier when both amplifiers are cascaded for a net gain of 7,500)	V_S	70	-	-	μV	$T_A = 25^{\circ}\text{C}$, with Amplifier Bandpass configuration as shown in Figure 3
Input Dynamic Range	-	0	-	2.5	V	-
Diff. Amp 2 Internal Reference	V_{IR}	-	$0.4V_R$	-	V	-
COMPARATOR:						
Lower Reference	V_{THL}	-	$0.3V_R$	-	V	-
Higher Reference	V_{THH}	-	$0.5V_R$	-	V	-
DIGITAL FILTER:						
Input Pulse Width (for recognition)	TPW	66.3	-	-	ms	60Hz operation
	TPW	79.6	-	-	ms	50Hz operation
INHIBIT INPUT:						
Inhibit Threshold	V_{THI}	-	$\geq 0.5V_{DD}$	-	V	-
Enable Threshold	V_{THE}	-	$\leq 0.45V_{DD}$	-	V	-
OSCILLATOR:						
Resistor	R_O	-	2.2	-	$\text{M}\Omega$	60Hz Oscillator Frequency
Capacitor	C_O	-	0.01	-	μF	
Resistor	R_O	-	4.3	-	$\text{M}\Omega$	30Hz Oscillator Frequency
Capacitor	C_O	-	0.01	-	μF	

PARAMETER	SYMBOL	MIN	TYP	MAX	UNIT	CONDITIONS
OUTPUT DRIVE CURRENT:						
Triac (AC MODE)	I_o	-40	-	-	mA	With 3V Triac Gate Drive
Relay (DC MODE)	I_o	-10	-	-	mA	With 1V Max. across the LS6501LP.
TRIAC OUTPUT TIMING:						
Pulse Width	T_{TPW}	15	30	45	μs	$V_{DD} = 8V$, $f = 60Hz$ and 2.7V P-P AC input
Delay from zero crossover	TOD	1.00	1.2	1.32	ms	
Delay difference between zero crossovers	TODD	-	-	150	μs	$f = 60Hz$
AC INPUT IMPEDANCE						
ZAC	ZAC	270	-	-	k Ω	-
LED OUTPUT:						
Sink Current	I_{LS}	-	-	8	mA	$V_{DD} = 8V$, $V_o = 1.5V$ Max.
Pulse Width	T_{LPW}	0.75	1	1.25	sec	$f = 60Hz$.
DUAL PULSE MODE:						
Time between pulse-pairs for motion recognition	T_R	-	-	5.125	sec	-

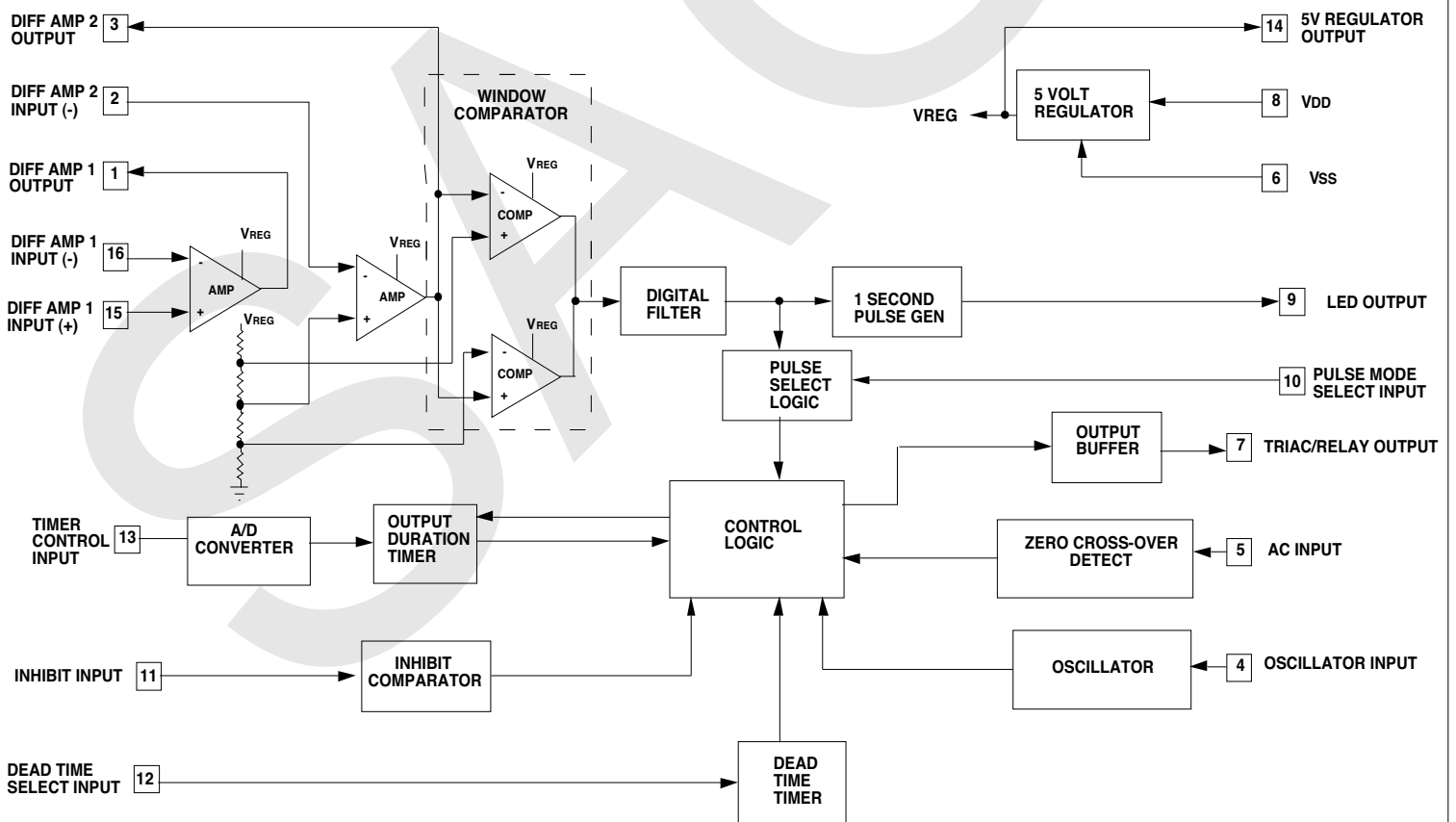
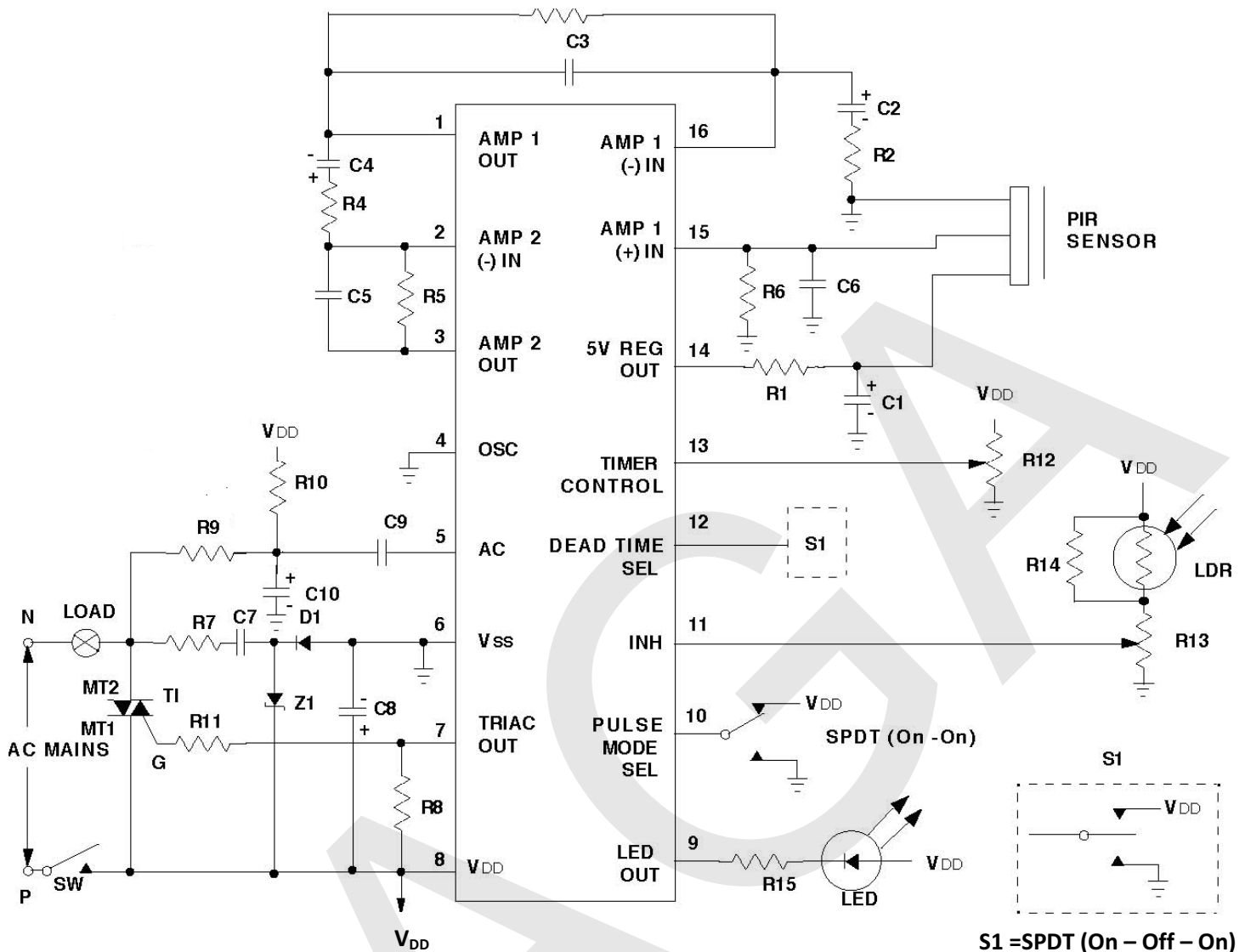

FIGURE 2. LS6522 BLOCK DIAGRAM



- | | | | |
|--------------------------|----------------------|--------------------------|-----------------------------------|
| R1 = 36k Ω | R8 = 1k Ω | C1 = 100 μ F | C8 = 1000pF |
| R2 = 36k Ω | R9 = 620k Ω | C2 = 33 μ F | C9 = 0.1 μ F, 250V |
| R3 = 2.7M Ω | R10 = 6.2k Ω | C3 = 0.01 μ F | *C9 = 0.1 μ F, 400V |
| R4 = 36k Ω | *R10 = 3.9k Ω | C4 = 33 μ F | C10 = 0.02 μ F, 25V |
| R5 = 2.7M Ω | R12 = 1M Ω | C5 = 0.01 μ F | *C10 = 0.03 μ F, 25V |
| R6 = 36k Ω | R13 = 1.0M Ω | C6 = 0.1 μ F | D1 = 1N4004 |
| R7 = 270 Ω , 1/2W | R14 = 910k Ω | C7 = 0.47 μ F, 250V | LDR = SILONEX HSL-19M52 (Typical) |
| * R7 = 1k, 1W | R15 = 3.6k Ω | *C7 = 0.33 μ F, 400V | Z1 = 9.1V, 1/2W |
| | | | T1 = Q4008L4(Typical) |
| | | | T1 = Q5004L4(Typical) |

All Rs 1/4W, all Capacitors 10V unless otherwise specified.

PIRs = Perkin-Elmer LHi 958 or 878, Nicera RE200B, SDA02-54 (Typical)

*= Component Change for 220VAC

- NOTES:**
- The R9, R10, C9 network provides a 2.7V Peak-to-Peak AC signal input to Pin 5.
 - The C8, D1, Z1, C7, R7 components generate the DC Supply Voltage for the LS6522.
 - The R2, C2, R3, C3, R4, C4, R5, C5, R6, C6 components and the two on-chip Differential amplifiers set a nominal gain of 5,500 with bandpass filtering of 0.13Hz to 6Hz.
 - The value of R6 may have to be adjusted if the particular PIR Sensor selected causes the input static voltage at Pin 15 to be out of the input dynamic range. This is specified under Electrical Characteristics as 0V to 2.5V.
 - Sensitivity can be adjusted to a lower value by increasing the value of R2 or R4 or by decreasing the value of R3 or R5.

FIGURE 3. TYPICAL TRIAC WALL SWITCH APPLICATION

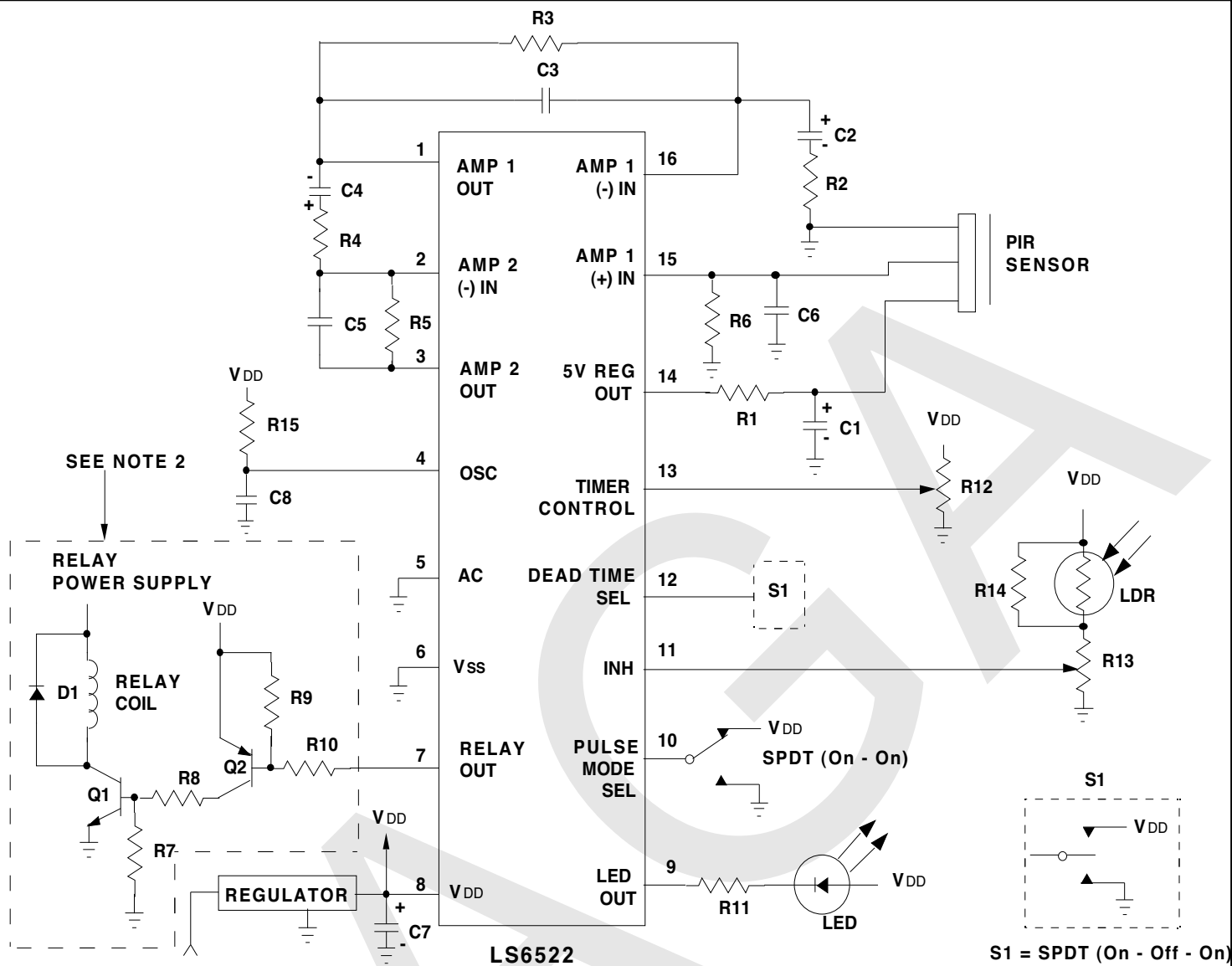

S1 = SPDT (On - Off - On)

- | | | | |
|------------|-------------|-------------|-----------------------------------|
| R1 = 36kΩ | R8 = 3.6kΩ | C1 = 100μF | C8 = 0.01μF |
| R2 = 36kΩ | R9 = 10kΩ | C2 = 33μF | LDR = SILONEX NSL-19M51 (Typical) |
| R3 = 2.7MΩ | R10 = 18kΩ | C3 = 0.01μF | Q1 = 2N3904 |
| R4 = 36kΩ | R11 = 3.6kΩ | C4 = 33μF | Q2 = 2N3906 |
| R5 = 2.7MΩ | R12 = 1.0MΩ | C5 = 0.01μF | REGULATOR = MC78L08 (Typical) |
| R6 = 36kΩ | R13 = 1.0MΩ | C6 = 0.1μF | RELAY = No typical P/N |
| R7 = 10kΩ | R14 = 910kΩ | C7 = 100μF | |
| | R15 = 2.4MΩ | | |

PIRs = Perkin-Elmer LHi 958, 878; Nicera RE200B, SDA02-54 (Typical)

All Resistors 1/4W, all Capacitors 10V

- NOTES:**
- The "Raw DC Voltage" into the Regulator can range between 11V and 25V and generates an 8V DC Supply Voltage for the LS6522.
 - The R10, R9, Q2, R8, R7, Q1 components interface LS6522 Pin 7 to a Relay Coil returned to a separate High-Voltage DC Supply.
 - A Relay Coil returned to a maximum of 12.5V can be directly driven by the LS6522 Pin 7.

FIGURE 4. TYPICAL DC RELAY APPLICATION

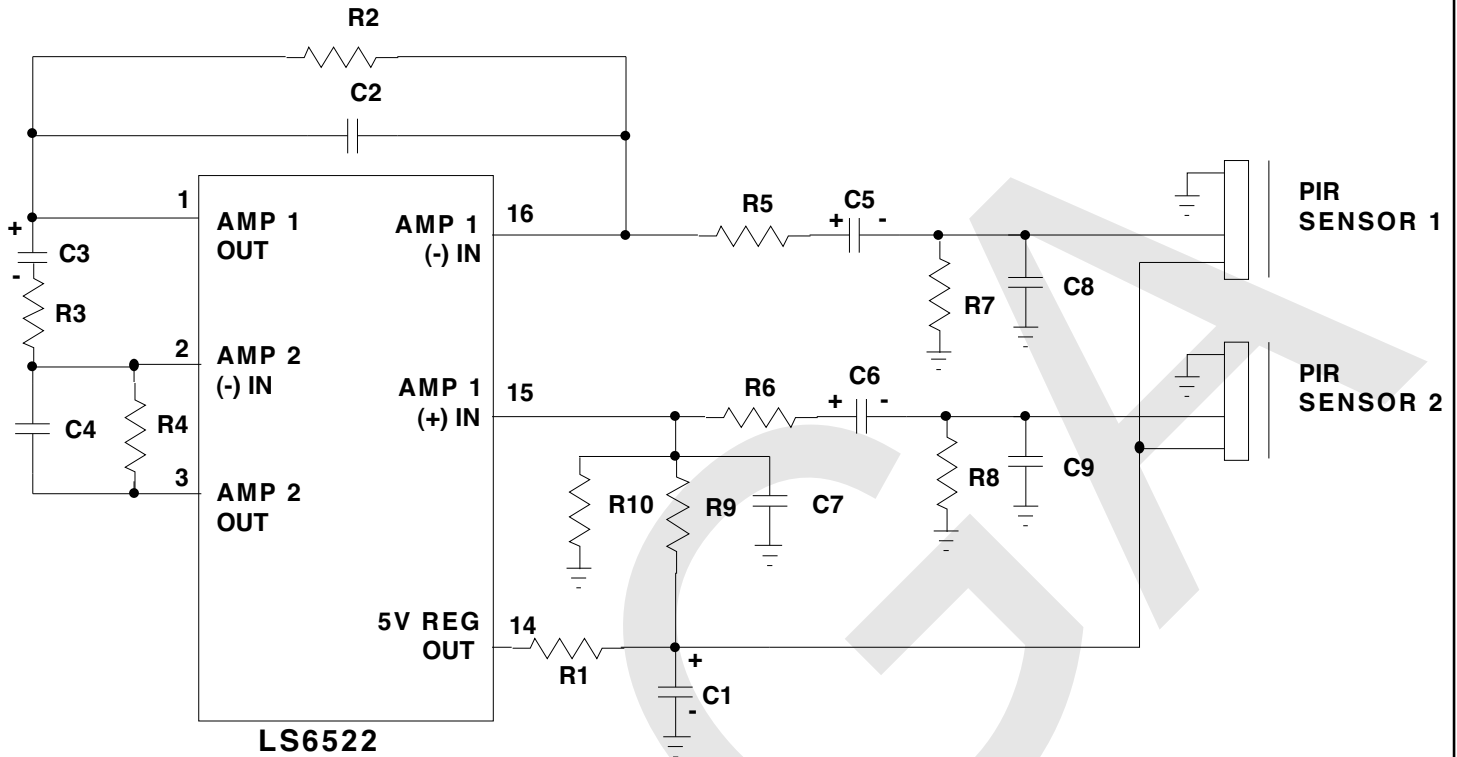

R1 = 36k Ω
 R2 = 2.7M Ω
 R3 = 36k Ω
 R4 = 2.7M Ω
 R5 = 36k Ω
 R6 = 36k Ω
 R7 = 36k Ω
 R8 = 36k Ω
 R9 = 5.6M Ω
 R10 = 5.6M Ω

C1 = 100 μ F
 C2 = 0.01 μ F
 C3 = 33 μ F
 C4 = 0.01 μ F
 C5 = 33 μ F
 C6 = 33 μ F
 C7 = 0.01 μ F
 C8 = 0.1 μ F
 C9 = 0.1 μ F

PIRs = Perkin-Elmer LHi 958, 878; Nicera RE200B, SDA02-54 (Typical)

All Resistors 1/4 W. All Capacitors 10V

NOTE: A pair of PIR Sensors may be used in applications where a wider optical field of view is needed.

FIGURE 5. LS6522 DIFFERENTIAL INTERFACE TO PIR SENSOR PAIR

The information included herein is believed to be accurate and reliable. However, LSI Computer Systems, Inc. assumes no responsibilities for inaccuracies, nor for any infringements of patent rights of others which may result from its use.

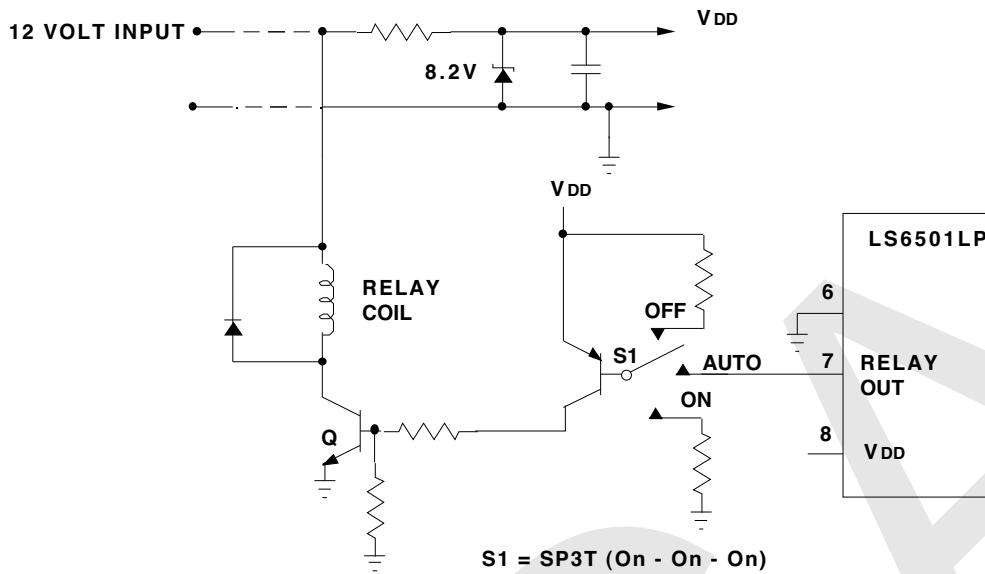

FIGURE 6. LOW VOLTAGE INDUSTRIAL CONTROL

For industrial applications a 12 Volt DC power supply can be used to power one or several low voltage PIR modules for many types of motion detection requirements. The low voltage, low current switch S1 provides ON/OFF/AUTO control of the Relay Coil.

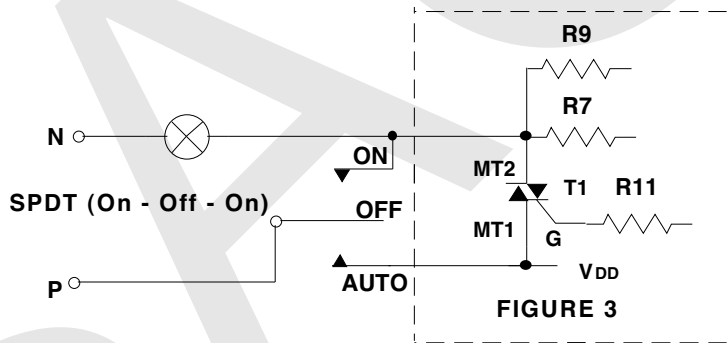

FIGURE 7. AIR-GAP SWITCH CONTROL

The application as shown in Figure 3 can be modified with the addition of a single pole, three position switch which provides for ON/OFF/AUTO control and also for the air-gap safety switch required by UL.